

10,000 POUND DUAL VESSEL GAC ADSORPTION SYSTEM

Bastrop County Water Control & Improvement District #2 (BCWCID2)

Request for Proposals (RFP) for Granular Activated Carbon Adsorption System as described herein.

Posted and Published on May 24, 2021

1.0. SCOPE OF WORK GENERAL DESCRIPTION

This specification describes all pre-engineered equipment to be provided for a complete operable GAC (Granular Activated Carbon) Adsorption System as manufactured. The Dual Vessel Adsorption System shall include two-stage (lead/lag) and parallel flow pattern operation for maximum carbon utilization. The system shall be designed to accept a flow up to 350 gallons-perminute (GPM) and the design shall include allowance for effective backwash capacity for up to 30% bed expansion during backwash.

The Carbon Adsorption System Supplier (SUPPLIER) shall be responsible for a complete system that is pre-piped and ready to be set in place. The supplier is responsible, as defined herein, for the design, fabrication, installation, assistance and startup of the system consisting of adsorbers, piping, and instrumentation. BCWCID2 will supply a concrete pad once necessary size has been determined.

1.1. ADSORPTION SYSTEM GENERAL DESIGN

The GAC adsorption system design shall provide for 10,000-pound carbon capacity for each adsorber (20,000-pound carbon capacity system design).

The process piping battery limits of this system end with the influent, effluent, backwash and vent connection flanges at the fabricated pipe module.

1.2. SCOPE of WORK

This Scope of Work shall include the supply of all equipment necessary to comprise a complete dual vessel adsorption system:

1.2.1. Two (2) 8-foot diameter down flow design carbon adsorbers with an internal underdrain. Adsorbers shall be ASME code pressure vessels rated for 125 psig with corrosion and abrasion resistant internal lining (see Section 3.1).

1.2.2. Six (6) inch diameter carbon steel process (influent, effluent and backwash) piping with flanged cast iron pipe fittings. The piping and valve arrangement shall be provided on a pipe rack module and shall allow for three modes of operation.

First, either of the two adsorbers can be positioned as the lead adsorber in a system series flow configuration; secondly, both adsorbers can be simultaneously operated in a system parallel flow configuration with each adsorber receiving one-half of the total flow to the system and thirdly, each adsorber can individually and independently operate as a single stage adsorber.

Operational modes shall be accomplished by opening/closing process valves included with the pipe rack module. The valve configuration shall permit adsorber isolation to accommodate carbon exchange or backwash functions while maintaining treatment operation.

1.2.3. Independent GAC fill and discharge piping including full bore stainless steel shutoff valves, flush connections and transfer hose connections.

1.2.4. Vent, pressure relief, flush water and motive air connections for GAC transfers, pressure gauges and sample points.

1.2.5. Delivery, Off-loading, rigging, setting in place and anchoring of all delivered system components, of the Adsorption System

1.2.6. One (1) complete set of technical specifications including General Arrangement Drawing, Flow Diagram and Adsorber Drawing and a digital copy of the Operation and Maintenance Manual

1.2.7. Assembly of system components including terminating pipe sections between the vessels and the pipe rack module.

10,000 POUND DUAL VESSEL GAC ADSORPTION SYSTEM

1.2.8. Training of Site operators by qualified SUPPLIER personnel.

1.3. WORK TO BE PROVIDED BY BCWCID2

1.3.1. Foundation design, foundation construction including pre-embedded anchor bolts once pre-construction details and measurements are provided.

1.3.2. Influent or backwash supply piping and effluent or backwash discharge piping including utility air or water piping.

1.3.3. Winterization including insulation, heat tracing or buildings.

1.4 PROJECT SUBMITTALS

To assure that the Pre-Engineered Modular Adsorption System will satisfy all the technical requirements of the site condition and treatment process both design and technical content submittals shall be provided TO THE BUYER, BCWCID #2 at key points in the project implementation process.

These project submittals are required with the bid/proposal;

1.4.1. Scope of Supply and general equipment/material specifications.

1.4.2. Flow Diagram showing system flow patterns and instrumentation. Flow Diagram shall include line sizes, valve arrangement, utility line sizes and all interface points needed for external piping.

1.4.3. Equipment Arrangement Drawing showing battery limit location(s), overall system dimensions, system weight and recommended foundation requirements.

1.4.4. Seller General Terms of Sale.

1.5 CONTRACT PURCHASE DOCUMENTATION

Within ten (10) working days after receiving purchase order authorization to proceed, the SUPPLIER shall submit drawings and other information, as listed herein, to the BUYER for the purpose of affirmation that SUPPLIER's offer conforms to these specifications. BUYER shall return approval by Purchase Order (P.O.) to SUPPLIER in ten (10) working days after receipt of drawings. BUYER approval shall include release to SUPPLIER to initiate fabrication of carbon adsorption system defined herein. Delivery of the carbon adsorption system to the site designated described herein, is desired to be within twenty-four (24) calendar weeks, or sooner, from SUPPLIER after receipt of authorization to begin fabrication work. Delivery time of less than twenty four (24) weeks shall be in accordance with written agreement of both BUYER and SUPPLIER at the time of purchase order award. BUYER may request SUPPLIER to adjust the scope of supply. Scope of Supply adjustments will be acknowledged with a written change notice and addendum to the initial purchase order authorization. Pricing and/or delivery adjustments shall be acknowledged by the purchase order addendum.

10,000 POUND DUAL VESSEL GAC ADSORPTION SYSTEM

1.5.1. Piping and Instrumentation Flow Diagram Drawing with notations for materials, valves, instruments and system accessories.

1.5.2. General Arrangement, Plans and Elevations Drawing with dimensional interface connection points including detail and location of base anchor bolt holes.

1.5.3. Adsorber Vessel and Underdrain Drawing showing nozzle schedule and ASME Code information. (The ASME Data Sheet shall be included with the Operating manual after shipment is made.)

1.5.4. Bill of Materials for all components and any other special materials supplied with the system including written specification description and/or catalog cut sheets of all equipment items being supplied.

1.5.5. List of recommended spare parts, identifying those spare parts that are available from the supplier.

1.6 OPERATING MANUAL

Before delivery and startup of the Carbon Adsorption System, one electronic copy of the Operation and Maintenance Manual shall be provided by the SUPPLIER. This manual shall incorporate all pertinent data relating to prior exchange of drawing and technical information beginning with the purchase order award. The Operating section of this manual shall include complete instructions describing staging of adsorbers and back washing of the carbon bed. The manual shall also include identification of SUPPLIER personnel available to BUYER for on-going technical support.

2. PROCESS DESCRIPTION

2.1. Carbon Adsorption

This Adsorption System shall be designed to use granular activated carbon (GAC) for efficient removal of dissolved organic chemical compounds from liquid. Primarily, we are treating contaminants of chloroform, bromoform and their chemical counterparts, that activate with chlorine, causing TTHM issues and have determined through pilot testing, that a GAC adsorption system is our best solution.

This Carbon Adsorption System, consists of two process adsorbers (vessels) and the system pipe network to allow the adsorbers to be operated in either a series (lead/lag) or parallel mode. Each adsorber shall be capable of containing twenty thousand (20,000) pounds of granular activated carbon.

Influent liquid flow in the adsorbers shall be from the top inlet distributor of the vessels with down flow through the granular activated carbon materials. An internal underdrain collection system at the bottom of the adsorber shall be designed supplied to allow passage of treated liquid out of the adsorber while retaining the media in the vessel. The underdrain collection system shall provide a method for removing the clean treated fluids and permit a uniform flow of water for backwashing media.

Due to the inefficient carbon utilization with an internal cone distributor, internal cone bottoms shall not be permitted.

See attached drawings.

10,000 POUND DUAL VESSEL GAC ADSORPTION SYSTEM

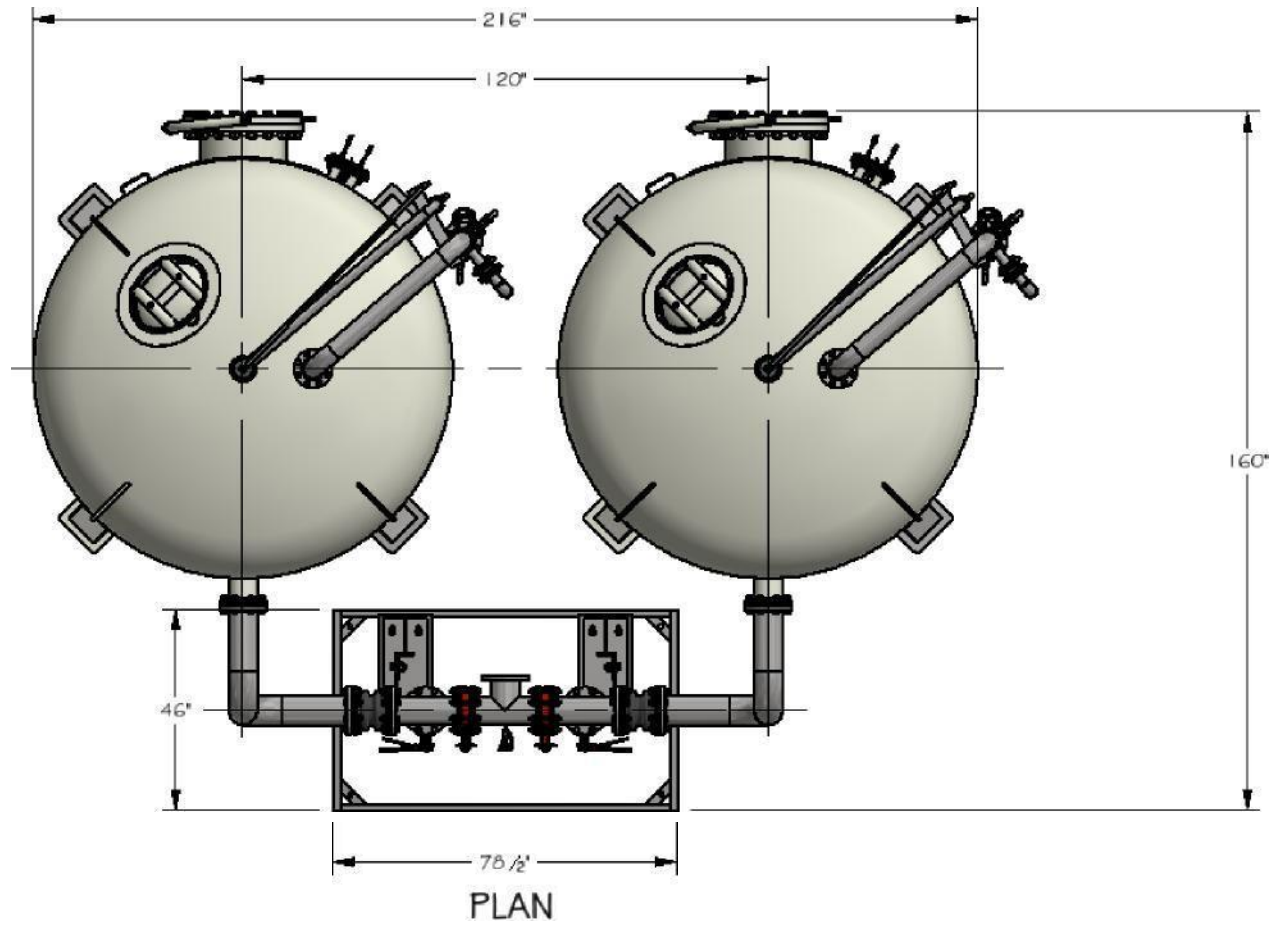

10,000 POUND DUAL VESSEL GAC ADSORPTION SYSTEM

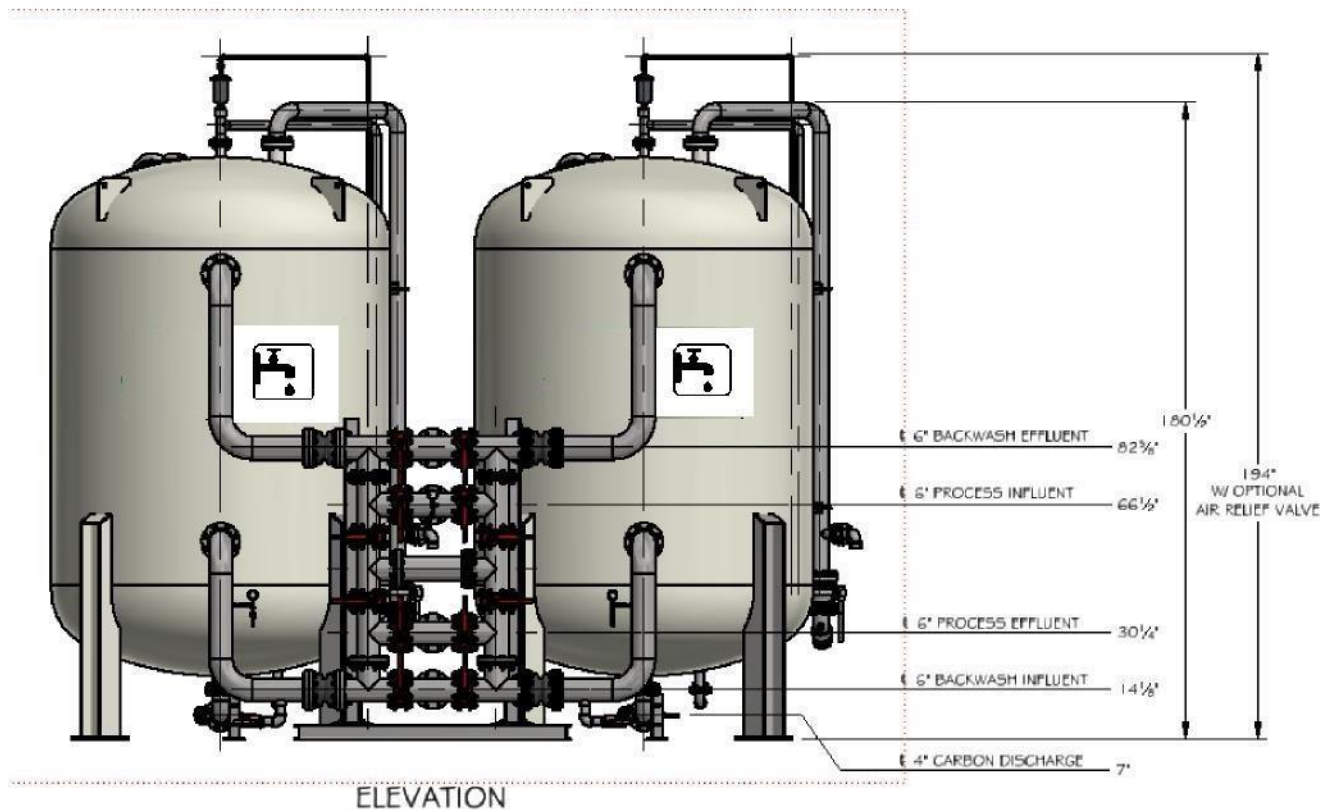

3. EQUIPMENT DESCRIPTION

3.1. Adsorber Vessels *

Adsorber vessels shall be 8 foot diameter x 8 foot straight side, vertical cylindrical pressure vessels with 2:1 elliptical top and bottom heads and four "I" beam legs. Each adsorber shall be designed, constructed and stamped in accordance with the ASME Code, Section VIII with design pressure rating of 125 psig at 150 degrees F. Each adsorber shall include one 20" diameter round, flanged manway on the lower straight side and one 14" x 18" elliptical manway on the top head.

Each adsorber shall have four "I" beam legs coped to the bottom head, and at a minimum, shall be W8 x 35 members (Note: actual design shall be based upon local building codes for wind and seismic conditions). Each leg shall have a 12" wide x 12" long x 1" thick base plate continuously welded to the structural leg at the bottom to allow for anchoring to a base pad.

10,000 POUND DUAL VESSEL GAC ADSORPTION SYSTEM

Each adsorber shall include 4" nozzles for carbon fill and carbon discharge, and 6" nozzles for influent and effluent connection. The backwash source connection to an integral pipe rack shall be provided and piping designed to allow backwash water to enter into the outlet nozzle on the bottom side shell of the vessel and exit out the top 6" flange on the top side shell of the vessel.

Each adsorber shall be designed to allow slurry or dry carbon fill and shall be capable of being slurry emptied through a bottom carbon discharge line or vacuumed through the top elliptical manway.

All nozzle connections shall include 150 pound external fittings and shall be installed such that all welds are ground flush on the inside of the adsorber steel.

Each adsorber is fabricated of carbon steel construction typically using SA-516-70 steel. All skip and full penetration welds, sharp edges, scabs, slivers and slag shall be corrected (removed and/or ground smooth) for lining surface preparation. All surfaces shall be degreased prior to surface preparation. The adsorber internal surface will be blasted to a white metal surface (SSPC-SP5) to provide an anchor pattern in the metal corresponding to a degree of profile of 4 mils, minimum. The exterior of the adsorber is sandblasted or power tool cleaned to the degree specified by SSPC-SP2-63.

Following completion of sandblasting, the interior surface shall be lined with a thick film catalyzed vinyl ester coating (Plasite 4110 or equal). Application of this lining material in conformance with the manufacturer's instructions shall produce a 35-45 mil dry film thickness. Inspection of the lining shall be done with a Tinker Razor high voltage tester to prove a pinhole free lining exists throughout the interior of the vessel.

Each adsorber shall be finish painted with a single coat of two-part catalyzed epoxy followed by a urethane top coat (Carboguard 891 HS/Carbothane 134HG) of approximately 4/2 mils. The final DFT shall be approximately 6 – 10 mils.

Due to the inability to properly line (pin hole free and NSF certified) under a cone bottom, an internal cone shall not be permitted.

3.2. Underdrain Collection System*

Each adsorber shall be equipped with a 6" schedule 10 304 stainless steel with 1 1/2" diameter wedge wire laterals. The laterals should be constructed of 316SS .065 triangular wire with a slot opening of .008". There shall be a minimum of 16 – 1 1/2" diameter laterals.

3.3 Inlet water distributor*

Each adsorber unit shall have an 6" PVC top inlet header designed with outlets have an open area equal to or greater than the inlet nozzle. This header is used to distribute water across the 8ft diameter of the vessel.

* = THE OVERALL DESIGN CRITERIA FOR THE VESSELS, UNDERDRAIN AND INLET STRUCTURE, PER MANUFACTURER, MAY BE DIFFERENT THEN DESCRIBED ABOVE DUE TO EACH MANUFACTURERS INDEPENDENT DESIGN. WE WILL ALLOW VARIATIONS IN DESIGN CRITERIA AS LONG AS THE BASIS OF THE TREATMENT AND LEAD/LAG OPERATION IS MANITAINED OVERALL FOR THE PROJECT.

3.4. Piping

3.4.1 Process

A process pipe network shall be designed to allow the adsorber system to operate in different modes. Normal operation shall allow fluid flows in series operation. Interconnecting process piping shall allow either adsorber to be operated in the lead position with the effluent from the lead adsorber to be directed to the influent adsorber nozzle of the lag adsorber. The effluent from the lag adsorber shall

10,000 POUND DUAL VESSEL GAC ADSORPTION SYSTEM

be piped to the system effluent connection at the battery limit.

The process pipe network shall allow parallel flow with valve adjustments. After flowing through the two carbon beds the effluent from each adsorber is combined by the pipe network to a single system effluent connection point.

During parallel operation, a flow use of both adsorbers shall produce a lower or equal pressure drop as during series flow. In either case, the total system pressure drop shall be less than 15 psig.

3.4.2. Adsorber Backwash

The pipe network shall allow a backwash operation for each adsorber in the event of an unacceptable pressure drop resulting from accumulation of suspended solids in the carbon bed. The adsorber requiring backwash shall be isolated from the system process flow. (NOTE: During series flow if the lead bed is backwashed the entire process flow shall be capable of shut off). A backwash (in) water connection to the carbon adsorption system shall be provided to allow an uncontaminated backwash water source to be piped to the pipe rack module. Piping shall be capable of conveying backwash water to produce approximately a 30% bed expansion. Backwash water shall exit the top of the carbon bed and flow through the pipe network to the backwash out connection point.

3.4.3. Process and Utility Piping

The process and backwash pipe shall be 6" diameter. Carbon fill and discharge piping shall be 4" diameter. Other connection points shall be provided for vent and pressure relief functions, and utility flush water, air, sample, and instrument connection points.

All process and carbon transfer fill piping shall be constructed of carbon steel. All pipe shall be ASTM A53, Grade B, schedule 40 material, rated for 150 psig @ 500 DEG F. Pipe flange fittings shall be ASTM A105 slip-on or weld neck. Other process pipe fittings such as tees and elbows shall be flanged, ASTM A126, 125 pound, Class B. The carbon discharge pipe from the adsorber nozzle to the carbon isolation valve shall be 304 stainless steel, schedule 10 pipe rated for 150 psig at 225 DEG F. Utility connections shall be 3/4" diameter weld-o-lets for steel pipe. Each utility connection point shall include a 3/4" pipe nipple.

Gaskets shall be 1/8" thick, EPDM.

The process pipe network shall include four (4), 6" diameter molded rubber expansion joints, for ease of installation. Each expansion joint shall be a Proco Style 242 molded spherical joint.

Exterior pipe surfaces shall be brush blasted to SSPC 6 and coated with International epoxy 670HS (or equal) with a top coat of International 990 HS urethane (or equal) top coat for a total 6 to 10 mil dry film thickness (6MDFT) of the finish exterior coating thickness.

3.4.4. Process, Carbon Transfer and Utility Valves

The process piping shall include positive shut-off valves for the purpose of isolation and flow control. Butterfly valves shall mate to Class 125 ANSI flanges. Butterfly valves shall be cast iron wafer body, rated for 200 psig @ 180 DEG F in the closed position, include a one piece aluminum bronze disc and 416SS shaft, Teflon shaft bushings and EPDM liner vulcanized to a hard phenolic backing. Valves shall be AWWA C-504 compliant.

Carbon transfer, fill and discharge isolation valves shall be corrosion and abrasion resistant to accommodate liquid slurry movement of carbon. Carbon shut-off valves shall be designed for manual operation, and shall be ANSI 150# flanged 316 stainless steel split body type with 316 stainless steel ball and stem (full port) with reinforced Teflon seats, Belleville spring-loaded RTFE stem packing, and Teflon body seals.

10,000 POUND DUAL VESSEL GAC ADSORPTION SYSTEM

Utility valves less than 2" diameter shall be provided for flush water connections, sample points, pressure gauge isolation and compressed air connections. These valves shall be constructed of bronze, forged brass or bar stock brass body, and be regular port ball valves, rated for 200 psig at 100 DEG F.

3.5. Miscellaneous Pipe System Specialty Accessories

3.5.1. Transfer Hose and Utility Quick Disconnect Adaptor Connections

The ends of the carbon transfer and fill pipe shall include Quick Disconnect Adaptor couplings. Transfer hose connectors shall be 4" diameter. Quick Disconnect Adaptors shall be employed to facilitate ease of slurry carbon transfers using flexible transfer hose between the adsorber carbon transfer pipe and pressurized carbon trailers. Utility water and air connections shall include 3/4" diameter quick disconnect adaptor. All Quick Disconnect Adaptors shall be stainless steel material.

3.5.2. Flush Water, Compressed Air, Sample Point Connections and Pressure Gauge Isolation

Utility connections shall be provided. One utility connection shall be provided on each side of the carbon transfer shutoff valve (6 total valves). An air utility connection shall be included at the adsorber influent pipe spool (2 total valves). A pressure gauge isolation/sample point valve arrangement to isolate pressure gauges and sample system water at three points (6 total valves) shall be provided. 3.5.3. Pressure Relief

The carbon vessel pressure relief shall be accomplished by way of a graphite rupture disk located in a separate vent line. One 3" graphite rupture disk per vessel is required. No valves or possible shut offs shall be provided between the rupture disk and the pressure vessel. Disks shall be sandwiched between two ANSI or ASME 150# flanges and rated for +/-5% of full scale on burst pressure. 3.6.

Instrumentation

Pressure Gauges

The system pipe network shall include three (3) pressure gauges to indicate water pressure at three positions of the carbon system: total system influent pressure, effluent water pressure and pressure between adsorbers. Each gauge shall be 4 1/2" face diameter, 0-150 psig range with accuracy of 1% of full range and includes a stainless-steel bourdon tube in glycerin filled stainless steel housing.

3.7. Pipe Frame Support

The prefabricated pre-engineered central pipe rack shall be attached by U-bolts to a pipe frame support. This pipe frame shall function as the central pipe rack support and also the base for attaching the prefabricated module to a foundation. The pipe frame shall consist of horizontal and vertical steel members. The carbon steel pipe frame shall be finish painted with 6 to 10 mil DFT epoxy/urethane paint system.

3.8 Pipe Rack Sample Points

The pipe rack module shall include four (4) sample points. The sample points shall be employed to collect water at influent, intermediate, and effluent positions in the adsorption system. Each sample point shall be fabricated of carbon steel pipe. The sample point assembly shall include a 3/4" diameter pipe nipple with a 3/4" manual shutoff valve.

10,000 POUND DUAL VESSEL GAC ADSORPTION SYSTEM

4. SERVICES

4.1. Adsorption System Installation – Installation of the adsorption equipment shall be by others but the system supplier shall be available for consultation and site visits during this phase of the project.

4.2. Operator Training and Start-up Assistance

The Supplier shall offer the services of qualified company personnel for pre-startup inspection, on-site operator training and other assistance to the site personnel during total system startup. The Supplier shall include a single (separate time period) visit of (2) TWO days of on-site support in the field for this activity to be fully completed with several operators.

Bastrop County Water Control & Improvement District #2 (the "District") is posting a Request for Proposals from qualified firms and/or corporations and/or manufacturing companies for the purpose of, acquiring a 10k pound Dual Vessel Granular Activated Carbon Adsorption System. The successful entity, if any, shall be awarded the project, and the District holds the right to reject any and all proposals submitted. Qualified firms should submit all Proposals to the District before **4:00 p.m. on Friday, June 4, 2021.**

Proposals must be delivered to the following individual and address:

Paul Hightower, General Manager
Bastrop County Water Control & Improvement District #2
PO Box 708
106 Conference Drive
Bastrop, Texas 78602
512-321-1688
paul@bcwcid2.org

Late submittals will not be considered

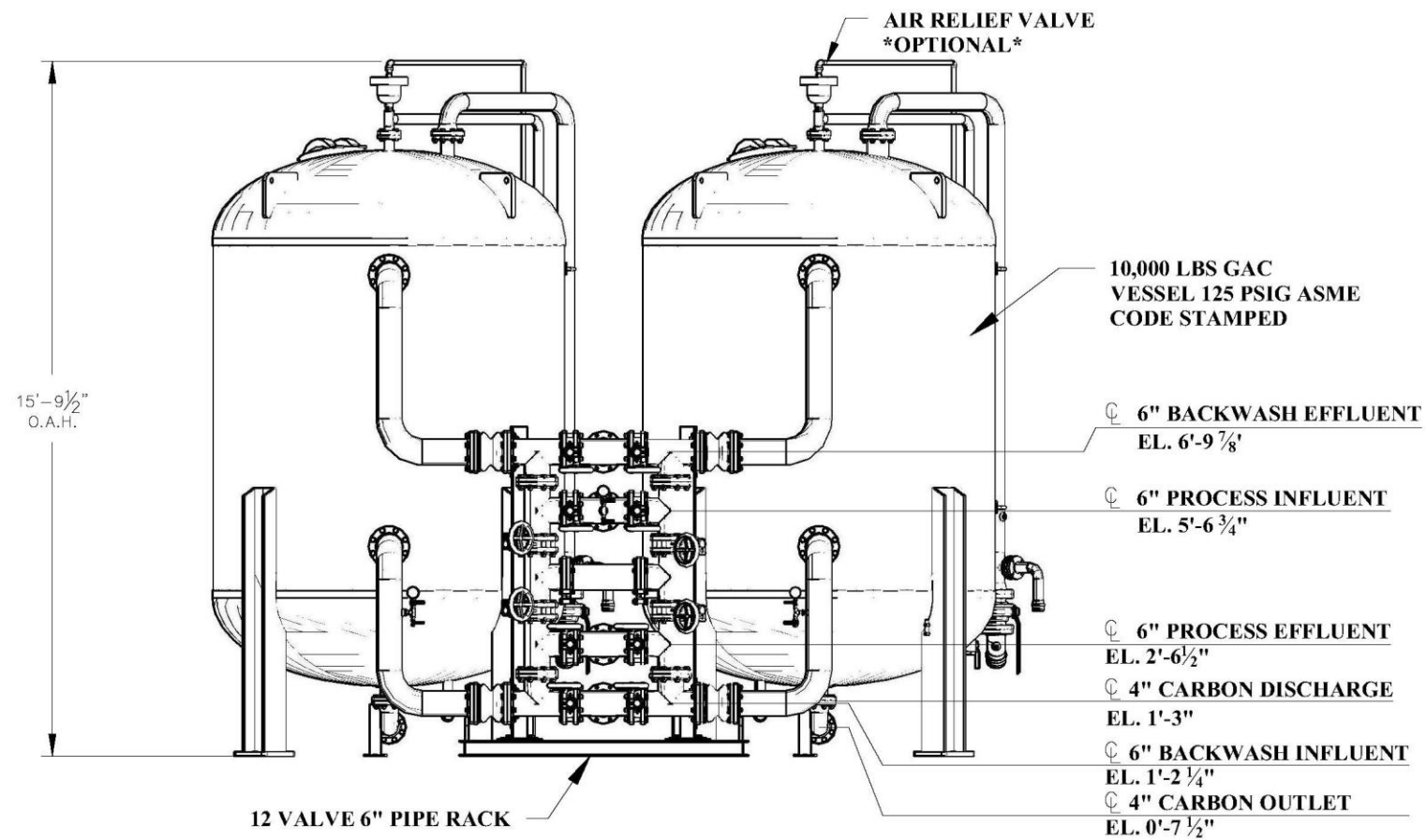

ELEVATION

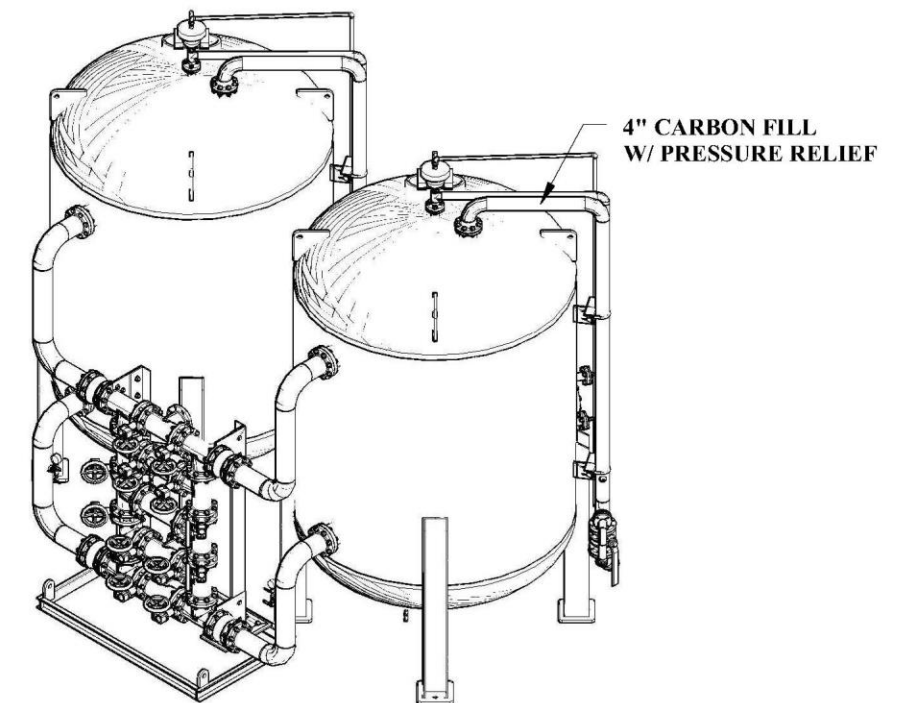

ISOMETRIC

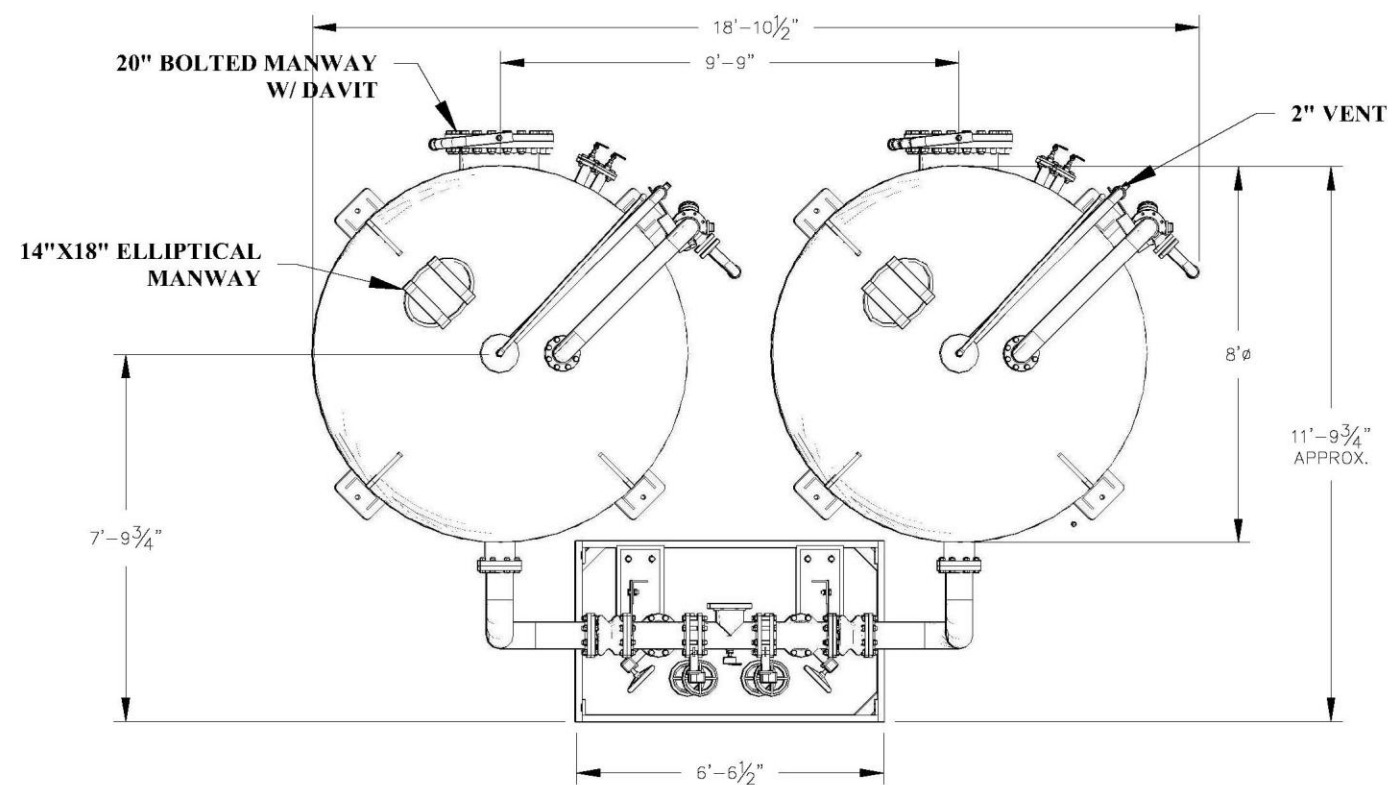

PLAN

PROJECT

NO.	REVISION	BY	DATE

SYSTEM GENERAL
ARRANGEMENT

REV. 0

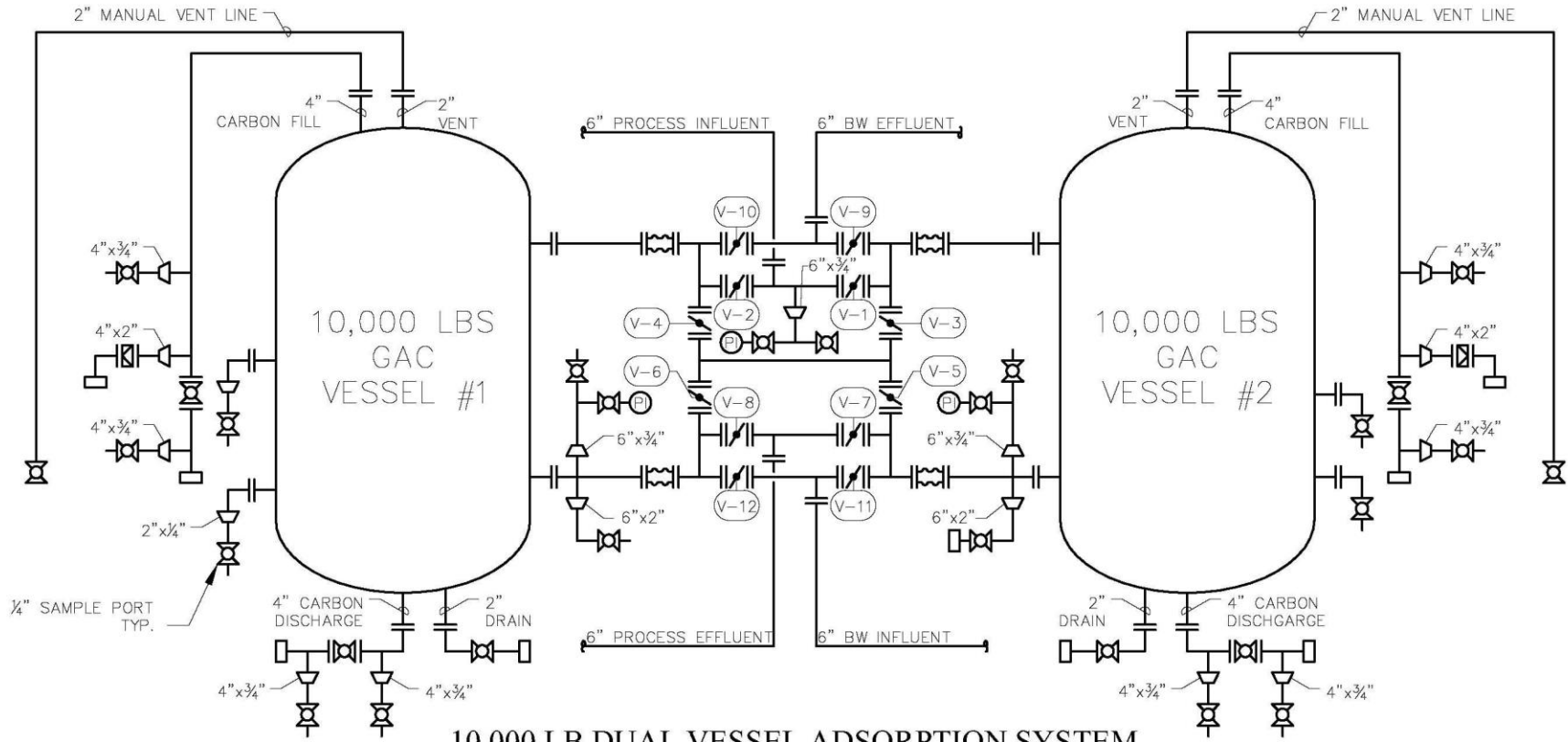

LEGEND

- | | | | |
|--------------------------------|-----------------------------------|----------------|------------|
| EXPANSION JOINT | REDUCER | RUPTURE DISK | BALL VALVE |
| QUICK CONNECT CAM LOCK FITTING | MANUALLY OPERATED BUTTERFLY VALVE | PRESSURE GAUGE | |

4				
3				
2				
1				
NO.	REVISION	BY	DATE	
PROJECT				
		REV. 0		